

A Structural Equation Model Analysis of Computing Identity Sub-Constructs and Student Academic Persistence

Mohsen Taheri¹, Monique Ross¹, Zahra Hazari^{2,3}, Mark Weiss¹

Michael Georgiopoulos⁴, Ken Christensen⁵, Tiana Solis¹, Atalie Garcia¹, Deepa Chari³

¹School of Computing and Information Sciences, Florida International University, Miami, USA

²Department of Teaching and Learning, Florida International University, Miami, USA

³STEM Transformation Institute, Florida International University, Miami, USA

⁴Department of Electrical Engineering and Computer Science, University of Central Florida, Orlando, USA

⁵Department of Computer Science and Engineering, University of South Florida, Tampa, USA

Abstract— This Research Full Paper presents the effects of computing identity sub-constructs on the persistence of computer science students. Computer science (CS) is one of the fastest growing disciplines in the world and an emerging critical field for all students to obtain vital skills to be successful in the 21st century. Despite the growing importance of computer science, many university and college programs suffer from low student persistence rates. Disciplinary identity is a theoretical framework that refers to how students see themselves with respect to a discipline and is related to long-term membership in a disciplinary community. The theory has been effectively applied in Science, Technology, Engineering, and Mathematics (STEM) to understand students' success and persistence. This study examines the effects of performance/competence, recognition, interest and sense of belonging on the academic persistence of computer science students. A survey of approximately 1,640 computing students as part of a National Science Foundation (NSF) funded project was developed and administered at three metropolitan public institutions. Confirmatory Factor Analysis (CFA) was performed to validate the sub-constructs of identity for use in a computing identity model. Then, a structural equation model (SEM) was constructed as a snapshot of the structural relationships for describing and quantifying the impact of the identity sub-constructs on persistence. The results indicated that our model for CS aligns with prior research on disciplinary identity but also adds the importance of sense of belonging. In addition, the findings indicate that students' academic persistence is directly influenced by their interest. A better understanding of these factors may leverage insight into students' academic persistence in computer science/engineering programs as well as a meaningful lens of analysis for further curriculum and extracurricular activities.

Keywords—computer science education; computing identity; academic persistence; structural equation modeling; engineering education.

I. INTRODUCTION

Computer technology and computing is part of everything we do from the daily work with cellphones, to the movies we watch. CS is one of the fastest growing disciplines and highest paying career paths in the world which enables us to make a positive difference in the world by driving innovation in the other sciences [1]. Despite the increasing popularity and demand

of computer science, many university programs suffer from low student persistence rates. The number of undergraduate students who leave Science, Technology, Engineering, and Mathematics (STEM) programs before completion is the highest for computer science majors (59%) compared to all other STEM disciplines [2]. Numerous students who leave computer science programs switch to other majors or drop out of school without earning an academic degree [2].

Literature specifies that academic persistence depends on a combination of factors such as the academic system, social system, family background, prior schooling [3-8], career interests [9], academic motivation [10], communities of practice [11], interest, self-efficacy [12-14], and many more. Social cognitive theory (SCT) [15] and social cognitive career theory (SCCT) [16] have also been prominent in STEM and engineering in the past decade emphasizing that self-beliefs explain students' academic choice behavior and influence students' performance, and career aspirations [17-19]. Other studies [20, 21] show that a student's identity or a student's self-perception of his/her performance, competence, interest, and recognition are notably related to his/her goals, institutional commitments, choice of career and persistence (Identity theory) (Fig1). One such identity is the disciplinary identity, a theoretical framework that refers to how students see themselves with respect to a discipline. The identity theory has been effectively applied in STEM to understand students' success, and persistence [17-21]. Although there has been extensive work in science and engineering there is a dearth of literature on the implications of computer science identity on persistence.

To address the persistence issue, this study examines the effects of performance, competence, recognition, and sense of belonging which for the purpose of this study are defined as "identity sub-constructs" on the academic persistence of computer science students. A sub-construct is an attribute, ability or skill that exists in the human brain, and is not directly observable [20]. For this examination, a survey was developed and administered at three metropolitan public institutions consisting of 1,640 computer science (CS), computer engineering (CE) and information technology (IT) students as part of a National Science Foundation (NSF) funded project

[Collaborative Research: Florida IT Pathways to Success (Flit-Path) NSF# 1643965]. The Confirmatory Factor Analysis (CFA) was performed first; then the structural equation model (SEM) was constructed to demonstrate and quantify the structural relationships of identity sub-constructs and persistence.

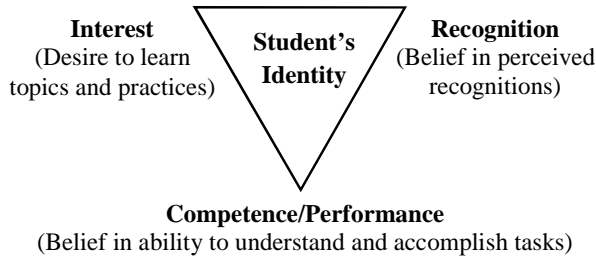

Fig. 1. Student's identity is composed of three sub-constructs which refer to student's self-perceptions.

The research question guiding the study was how the theorized identity sub-constructs (performance, competence, recognition, interest, and sense of belonging) contribute to the academic persistence of undergraduate computer students?

II. THEORETICAL FRAMEWORK

Identity development in STEM: Identity is an essential analytical instrument in education research for understanding students [22]. There has been increasing attention to identity development in STEM [23] due to a growing concern of the lack of interest in science among students. Identity has been defined as an individual's lens of past experience and performances in society and the world around them [24] or at the present time or even future envisioning [25, 26]. In 2007, a framework for science identity was proposed that emphasized performance, recognition and competence [27]. They developed a model of science identity to investigate the science experiences of students over the course of their education in science and science-related careers. Later, interest was introduced as another interrelated sub-construct that contributed to the framework [20] (Fig1). This framework has been validated for examining identity in the fields of math, physics, science and engineering. [17-21]. A student's desire to learn and study, perceived competence/performance and his/her beliefs of being recognized by others have been identified to be predictive of his/her persistence in education and career in that discipline [18]. Sense of belonging (belief in fitting into a community) on the other hand, has been identified as an additional effective construct on student identity and persistence [5, 28, 29] which in this work is applied to the framework and examined as an identity sub-construct. Computing identity: Although the STEM identity literature highlights the significance of self-beliefs in academic persistence and success [18-20, 27, 30-35], the research on computing identity has not been studied and framed widely. Researchers explored several areas as related to the computing identity such as self-perception of performance/competence, students' expectation and values [36-38], and measurement examination [39]. The computing identity literature is lacking rigorous studies and still demands a more in depth inquiry to indicate whether CS identity aligns with prior studies but also

whether the interrelated sub-constructs of computing identity influences CS students' persistence.

III. METHODOLOGY

A quantitative research method was used for this study. A survey exploring computing identity was developed and disseminated. The structural equation modeling (SEM) was used to determine whether the identity model was valid and how the theorized identity sub-constructs contribute to the academic persistence of computer science students [18]. After the institutional review board (IRB) approval, we first conducted a pre-survey on 95 students in three rounds. We revised some of the questions after the central tendency measurement, CFA analysis and follow-up conversation with some of the students. Then, we conducted the main Flit-Path survey which was given to 1640 undergraduate students ranging from freshmen to seniors at three metropolitan public institutions, Florida International University (FIU), University of Central Florida (UCF) and University of South Florida (USF). The final version of the survey included 22 questions that covered the theorized sub-constructs of computing identity, persistence likelihood and career likelihood and consisted of multiple choice, Likert-scale, and categorical questions. The survey responses included a wide range of students: 22% female, 78% male, 23% 1st year, 13% 2nd year, 27% 3rd year, 23% 4th year, 14% past 4th year. In addition, students consisted of 31 American Indian or Alaska Native, 254 Asian, 198 Black or African American, 505 Hispanic, Latin, or Spanish origin, 40 Middle Eastern or North African, 11 Native Hawaiian or Other Pacific Islander, 857 White, and 41 other race or ethnicity. The sample is not representative of the national population.

SEM is a quantitative multivariate statistical analysis technique consisting of multiple regression and factor analysis which utilizes measured variables and latent variables in complex relationships [40]. Measured variables such as our survey items can be observed and are measurable, while, latent variables such as persistence and identity sub-constructs cannot be observed directly, but their values can be implied by their relationships to observed variables. SEM builds on correlational research by adding theoretical perspectives of an explanatory nature that provides more insight into potential causation. The main reason for using SEM in this study is that SEM can measure latent variables and assesses the validity and reliability of the measurement model. In addition, it enables us to evaluate a model of relationships among constructs and sub-constructs simultaneously [40]. The SEM first uses factor analysis to evaluate how well the items measure the underlying theoretical construct or latent variables. Then uses path analysis to evaluate the relationships among the latent variables and the validation of the model fit [18, 20].

In this study different aspects of reliability and validity were utilized. Face, content and construct validity were performed to determine whether our study truly measures what it intended to measure. A pre-survey was designed and developed by leveraging valid and reliable instruments in engineering and science [20, 21] to provide feedback and establish face and content validity [41]. We performed several changes incrementally to examine and modify some of the questions. We piloted the survey to ensure that the test was formatted correctly,

worded correctly and that the questions were valid. In terms of construct validity, a Confirmatory Factor Analysis (CFA) was applied to the survey to validate whether the suitable measures loaded on the four separate sub-constructs. In the construct validity we compared the test elements of sub-constructs to determine how correlated the measures were and how well our tool measured the sub-constructs. We set a minimum factor loading of 0.5 [17, 20, 42, 43] and the results showed high correlation in our four-factor design. In terms of reliability, an internal consistency test was performed on the items used to build the four identity sub-constructs. Cronbach's alpha for the interest and recognition, performance/competence and sense of belonging items were above the acceptable level of reliability of 0.7 [20, 21].

IV. RESULTS

CFA was performed to identify number and nature of underlying latent factors and examine the survey responses to confirm the factorial structure. We loaded questions into five factors. CFA confirmed three items for interest, three items for recognition, two items for performance/competence and two items for sense of belonging. Each item of the sub-constructs had a loading factor of 0.5 or greater [40, 43]. The CFA model was tested based on our theoretical understanding of prior qualitative work [27].

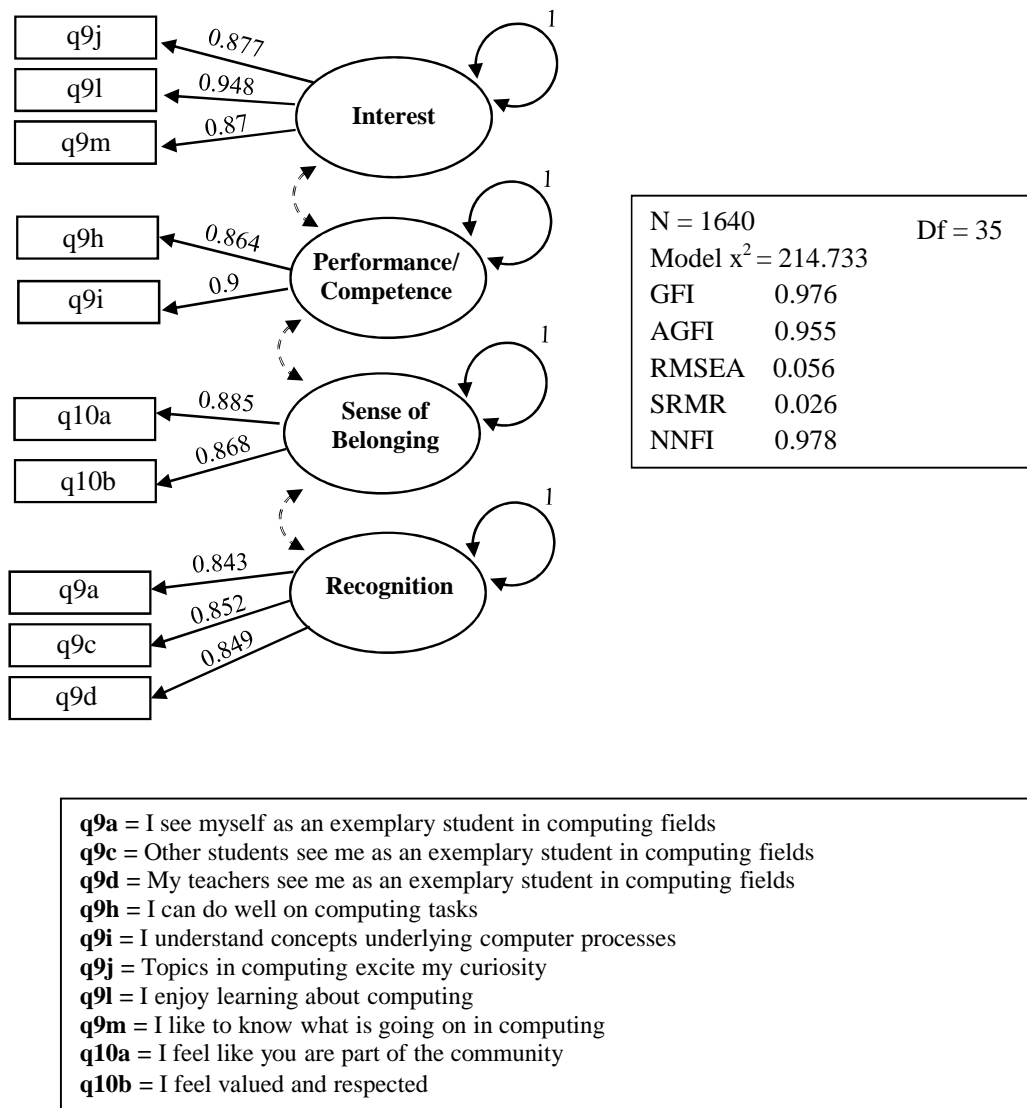

Fig. 2. Confirmatory factor analysis to confirm the factorial structures. (Acceptable values: GFI ($p > 0.90$), AGFI ($p > 0.90$), RMSEA ($p < 0.08$), NNFI ($p > 0.90$), SRMR ($p < 0.08$))

Measurement Model: The confirmatory factor analysis was performed using R open source software version 1.1.442. The SEM and Lavaan packages were used for measurement and the structural model. Bootstrapping and maximum likelihood estimation were used for our data to moderate the potential biasing effects for missingness [17, 42]. Due to the large data sample size, the chi-square is significant [43]. All of the fit indices of the model including GFI, AGFI, RMSEA, NNFI and SRMR were within the recommended range of SEM and engineering education scholars [18, 19, 43]. Figure 2 shows the initial measurement model and fit indices

Table 1 shows the results of the initial measurement model and fit indices. It includes the factor loadings, item reliability,

construct reliability and average invariance of variables. The range of standardized factor loading was from 0.84 to 1 which is acceptable [18, 43].

Structural model: We hypothesized a structural model for the identity sub-constructs and persistence. Figure 3 Shows the model which was input using a correlation matrix. The goal of SEM is to find the best model fit. We tested and hypothesized different combinations of sub-constructs based on the previous work on identity theory and social cognitive careers [12, 16, 17-21, 27]. The reference variable for computing persistence was fixed in the model to 1. All pathways were significant ($p < 0.001$) and fit indices were within the recommended range [18, 19, 43].

TABLE I. CONFIRMATORY FACTOR ANALYSIS ESTIMATES AND FIT INDICES

| Latent variable | Indicator variable | Standardized factor loading | Standard error | Item reliability (R ²) | Construct reliability | Average variance extracted |
|----------------------------|--------------------|-----------------------------|----------------|------------------------------------|-----------------------|----------------------------|
| Interest | q9j | 0.877 | 0.020 | 0.769 | 0.927 | 0.808 |
| | q9l | 0.948 | 0.017 | 0.899 | | |
| | q9m | 0.87 | 0.019 | 0.757 | | |
| Performance/ Competence | q9h | 0.864 | 0.025 | 0.746 | 0.875 | 0.778 |
| | q9i | 0.9 | 0.024 | 0.810 | | |
| Recognition | q9a | 0.843 | 0.021 | 0.711 | 0.885 | 0.719 |
| | q9c | 0.852 | 0.021 | 0.726 | | |
| | q9d | 0.849 | 0.021 | 0.721 | | |
| Sense of Belonging | q10a | 0.885 | 0.026 | 0.783 | 0.869 | 0.768 |
| | q10b | 0.868 | 0.025 | 0.753 | | |

Acceptable values: Item reliability > 0.50, Construct reliability > 0.70, Average variance extracted > 0.50

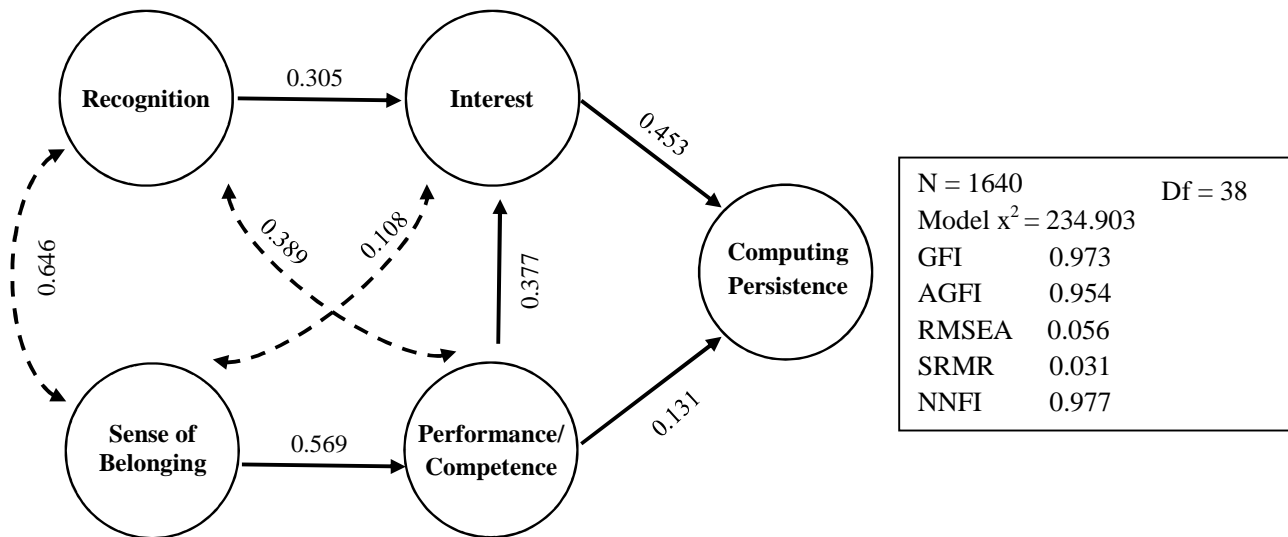

Fig. 3. Structural equation modeling results. GFI: goodness of fit; AGFI: adjusted goodness of fit; RMSEA: root mean square error of approximation; SRMR: standardized root mean square residual; NNFI: non-normed fit. (Acceptable values: GFI ($p > 0.90$), AGFI ($p > 0.90$), RMSEA ($p < 0.08$), NNFI ($p > 0.90$), SRMR ($p < 0.08$))

V. DISCUSSION

While computing identity sub-constructs contributed to persistence, their effects were varied with both direct and indirect pathways. Since the theoretical structure does not explain the nuance in how the sub-constructs affect each other and identity, we tested several direct and indirect models for the effect of the sub-construct. The interest had the strongest direct effect on persistence ($p < 0.001$) which indicates that the more students are interested in computing, the more likely they would be to persist. There is rich literature [45, 46] that emphasizes student's desire to learn computing and curiosity about computing topics are linked with student's persistence, engagement and motivation in computing.

Student's self-competency beliefs also had a significant pathway to persistence ($p < 0.001$). Students' beliefs about their ability to understand and perform in computing affects students' activities [15]. The direct effect of interest and competency is supported by SSCT and self-efficacy theory [47]. Students with higher self-competency beliefs are more likely to persist in learning, education, and occupation [48]. The effects of interest and self-efficacy on student's persistence and performance have been studied in many studies [49-53]. Recognition had both direct and indirect effects on persistence ($p < 0.001$). Recognition had a direct effect on interest ($p < 0.001$) which indicates that the more a student believes that their friends and family members view him/her as a computing person, the more likely he/she feels interested in computing [12]. The indirect influence of recognition on persistence went through interest. It indicates that recognition may increase student's persistence by influencing interest. For instance, being recognized by friends and teachers as a software developer for a computing student positively affects his/her interest and consecutively his/her persistence in academia and career intentions. Recognition and performance/competence have been studied as predictive of positively impacting students' persistence [18].

Sense of belonging had a direct effect on competence and performance ($p < 0.001$). It indicates that the more students feel a belonging to the computing community, groups and organizations, the more likely they feel they are capable to understand computer science and perform in computing. The strong correlation among recognition, sense of belonging and performance /competence revealed that there are bidirectional effects among them. If school administrators and teachers encourage students to be part of computing organizations like ACM and IEEE, it allows students to feel a sense of belonging in computing sciences.

The difference in our results to the expected identity framework [17-19, 21] may potentially be caused by multiple reasons. For example, the variation in CS interest for the students who study computing across IT, CS, and CE might suggest that interest level really distinguishes their likelihood of persisting in CS related careers. Students may be interested initially in CS careers for many reasons that are not related to the core interest in the subject. Thus, their original interest once in the programs may serve to distinguish them in ways that affect their persistence. For instance, a student who enters CS because he/she is interested initially in a career related to gaming, may realize once in the program that actual CS tasks are less

interesting and therefore be less likely to persist. In contrast, the model for students in engineering [17, 18] may be different because they initially major in those subjects with similar interests in the content itself. Second in this study, the focus was on persistence as an outcome rather than an overall measure for a student's disciplinary identity. Thus, we did not expect identical results from earlier work in physics, math and science.

Interest in this model has been identified as the most effective sub-construct with a direct pathway on persistence. The other sub-constructs indirectly affecting the interest sub-construct. For instance, if a student feels less recognized, he/she is more likely to drop out or choose an unrelated career due to the fact of not being interested in computing. It would be beneficial to investigate the theory in action and do further study about student's feelings and beliefs on their persistence.

VI. CONCLUSION

The purpose of this study was to investigate how computing identity sub-constructs contribute to the academic persistence of CS students. In addition, it aimed to examine whether the theorized sub-constructs aligns with the prior work on identity. For this purpose, we designed a conceptual model, developed a hypothesis, designed a questionnaire, conducted a survey, and used multiple statistical techniques including CFA and SEM to accomplish our goal and answer our research question. The results showed CS persistence is influenced by the computing identity sub-constructs. Structural equation modeling analysis quantified the impact of these pathways.

It is important to understand that investigating students' identity is one way to explore students' persistence. The model proposed in this paper will help researchers to understand students' persistence in computing through further exploring in their identity sub-constructs. In addition, constructing curricular and extracurricular activities based on these findings potentially increase the academic persistence in computer science programs. Furthermore, students, instructors, and faculty members, as well as academic counselors who assist and advise students can leverage the results. The future work includes further assessment of our structural equation model for diverse demographics such as gender dynamics and level of education.

ACKNOWLEDGMENT

This material is based upon work supported by the National Science Foundation [Collaborative Research: Florida IT Pathways to Success (Flit-Path) NSF# 1643965, 1643931, 1643835]. Any findings, conclusions, and recommendations expressed in this work do not necessarily reflect the views of the National Science Foundation.

REFERENCES

- [1] Schneider, G. M., & Gersting, J. (2018). Invitation to computer science. Cengage Learning.
- [2] G. Chen, X. (2013). STEM Attrition: College Students' Paths into and out of STEM Fields. Statistical Analysis Report. NCES 2014-001. National Center for Education Statistics.
- [3] Tinto, V. (1975). Dropout from higher education: A theoretical synthesis of recent research. *Review of educational research*, 45(1), 89-125.
- [4] Tinto, V. (1985). Dropping out and other forms of withdrawal from college. *Increasing student retention*, 2, 28-43.

- [5] Tinto, V. (1997). Classrooms as communities: Exploring the educational character of student persistence. *The Journal of higher education*, 68(6), 599-623.
- [6] Bean, J. P., & Eaton, S. B. (2000). A psychological model of college student retention. *Reworking the student departure puzzle*, 1, 48-61.
- [7] Bean, J. P. (2003). College student retention. *Encyclopedia of education*, 1, 401-407.
- [8] Bean, J., & Eaton, S. B. (2001). The psychology underlying successful retention practices. *Journal of College Student Retention: Research, Theory & Practice*, 3(1), 73-89.
- [9] Astin, A. W. (1993). *What matters in college?: Four critical years revisited* (Vol. 1). San Francisco: Jossey-Bass.
- [10] French, B. F., Immekus, J. C., & Oakes, W. C. (2005). An examination of indicators of engineering students' success and persistence. *Journal of Engineering Education*, 94(4), 419-425.
- [11] Lave, J., Wenger, E., & Wenger, E. (1991). *Situated learning: Legitimate peripheral participation* (Vol. 521423740). Cambridge: Cambridge university press.
- [12] Lent, R. W., Brown, S. D., & Hackett, G. (1994). Toward a unifying social cognitive theory of career and academic interest, choice, and performance. *Journal of vocational behavior*, 45(1), 79-122.
- [13] Gist, M. E., & Mitchell, T. R. (1992). Self-efficacy: A theoretical analysis of its determinants and malleability. *Academy of Management review*, 17(2), 183-211.
- [14] Cabrera, A. F., Nora, A., & Castaneda, M. B. (1992). The role of finances in the persistence process: A structural model. *Research in higher education*, 33(5), 571-593.
- [15] Bandura, A. (1986). *Social foundations of thought and action: A social cognitive theory*. Englewood Cliffs, NJ, US: Prentice-Hall, Inc.
- [16] Lent, R. W., Brown, S. D., & Hackett, G. (2002). Social cognitive career theory. *Career choice and development*, 4, 255-311.
- [17] Godwin, A., Potvin, G., Hazari, Z., & Lock, R. (2013, October). Understanding engineering identity through structural equation modeling. In *Frontiers in Education Conference, 2013 IEEE* (pp. 50-56). IEEE.
- [18] Godwin, A., Potvin, G., Hazari, Z., & Lock, R. (2016). Identity, critical agency, and engineering: An affective model for predicting engineering as a career choice. *Journal of Engineering Education*, 105(2), 312-340.
- [19] (Cribbs, J. D., Hazari, Z., Sonnert, G., & Sadler, P. M. (2015). Establishing an explanatory model for Mathematics Identity. *Child development*, 86(4), 1048-1062.)
- [20] Hazari, Z., Sonnert, G., Sadler, P. M., & Shanahan, M. C. (2010). Connecting high school physics experiences, outcome expectations, physics identity, and physics career choice: A gender study. *Journal of research in science teaching*, 47(8), 978-1003.
- [21] Cass, C. A., Hazari, Z., Cribbs, J., Sadler, P. M., & Sonnert, G. (2011, October). Examining the impact of mathematics identity on the choice of engineering careers for male and female students. In *Frontiers in Education Conference (FIE), 2011* (pp. F2H-1). IEEE.
- [22] Gee, J. P. (2000). Chapter 3: Identity as an analytic lens for research in education. *Review of research in education*, 25(1), 99-125.
- [23] Tytler, R. (2014). Attitudes, identity, and aspirations toward science. *Handbook of research on science education*, 82-103.
- [24] Enyedy, N., Goldberg, J., & Welsh, K. M. (2006). Complex dilemmas of identity and practice. *Science Education*, 90(1), 68-93.
- [25] Shanahan, M. C. (2009). Identity in science learning: Exploring the attention given to agency and structure in studies of identity. *Studies in Science Education*, 45(1), 43-64.
- [26] Calabrese Barton, A., Kang, H., Tan, E., O'Neill, T. B., Bautista-Guerra, J., & Brecklin, C. (2013). Crafting a future in science: Tracing middle school girls' identity work over time and space. *American Educational Research Journal*, 50(1), 37-75.
- [27] Carlone, H. B., & Johnson, A. (2007). Understanding the science experiences of successful women of color: Science identity as an analytic lens. *Journal of research in science teaching*, 44(8), 1187-1218.
- [28] Lewis, K. L., Stout, J. G., Pollock, S. J., Finkelstein, N. D., & Ito, T. A. (2016). Fitting in or opting out: A review of key social-psychological factors influencing a sense of belonging for women in physics. *Physical Review Physics Education Research*, 12(2), 020110.
- [29] Trujillo, G., & Tanner, K. D. (2014). Considering the role of affect in learning: Monitoring students' self-efficacy, sense of belonging, and science identity. *CBE-Life Sciences Education*, 13(1), 6-15.
- [30] Aschbacher, P. R., Li, E., & Roth, E. J. (2010). Is science me? High school students' identities, participation and aspirations in science, engineering, and medicine. *Journal of Research in Science Teaching*, 47(5), 564-582.
- [31] Boaler, J. (2002). *Experiencing school mathematics: Traditional and reform approaches to teaching and their impact on student learning*. Routledge.
- [32] Capobianco, B. M., French, B. F., & Diefes-Du, H. A. (2012). Engineering identity development among pre-adolescent learners. *Journal of Engineering Education*, 101(4), 698-716.
- [33] Cobb, P., & Hodge, L. L. (2010). Culture, identity, and equity in the mathematics classroom. In *A journey in mathematics education research* (pp. 179-195). Springer, Dordrecht.
- [34] Varelas, M., Martin, D. B., & Kane, J. M. (2012). Content learning and identity construction: A framework to strengthen African American students' mathematics and science learning in urban elementary schools. *Human Development*, 55(5-6), 319-339.
- [35] Tonso, K. L. (1997). Constructing engineers through practice: Gendered features of learning and identity development.
- [36] Bell-Watkins, K., Barnes, T., & Thomas, N. (2009). Developing computing identity as a model for prioritizing dynamic K-12 computing curricular standards. *Journal of Computing Sciences in Colleges*, 24(3), 125-131.
- [37] James DiSalvo, B., Yardi, S., Guzdial, M., McKlin, T., Meadows, C., Perry, K., & Bruckman, A. (2011, May). African American men constructing computing identity. In *Proceedings of the SIGCHI Conference on Human Factors in Computing Systems* (pp. 2967-2970). ACM.
- [38] Mercier, E. M., Barron, B., & O'Connor, K. M. (2006). Images of self and others as computer users: The role of gender and experience. *Journal of computer assisted learning*, 22(5), 335-348.
- [39] Smith, J. L., Morgan, C. L., & White, P. H. (2005). Investigating a measure of computer technology domain identification: A tool for understanding gender differences and stereotypes. *Educational and Psychological Measurement*, 65(2), 336-355.
- [40] Wright, R. T., Campbell, D. E., Thatcher, J. B., & Roberts, N. H. (2012). Operationalizing Multidimensional Constructs in Structural Equation Modeling: Recommendations for IS Research. *CAIS*, 30, 23.
- [41] Haynes, S. N., Richard, D., & Kubany, E. S. (1995). Content validity in psychological assessment: A functional approach to concepts and methods. *Psychological assessment*, 7(3), 238.
- [42] Fox, J. (2006). Teacher's corner: structural equation modeling with the sem package in R. *Structural equation modeling*, 13(3), 465-486.
- [43] Schumacker, R. E., & Lomax, R. G. (2012). *A beginner's guide to structural equation modeling*. Routledge.
- [44] Hilton, T. L., & Lee, V. E. (1988). Student interest and persistence in science: Changes in the educational pipeline in the last decade. *The Journal of Higher Education*, 59(5), 510-526.
- [45] Lent, R. W., Lopez Jr, A. M., Lopez, F. G., & Sheu, H. B. (2008). Social cognitive career theory and the prediction of interests and choice goals in the computing disciplines. *Journal of Vocational Behavior*, 73(1), 52-62.
- [46] Biggers, M., Brauer, A., & Yilmaz, T. (2008, March). Student perceptions of computer science: a retention study comparing graduating seniors with cs leavers. In *ACM SIGCSE Bulletin* (Vol. 40, No. 1, pp. 402-406). ACM.
- [47] Bandura, A., & Schunk, D. H. (1981). Cultivating competence, self-efficacy, and intrinsic interest through proximal self-motivation. *Journal of personality and social psychology*, 41(3), 586.
- [48] Ferla, J., Valcke, M., & Schuyten, G. (2010). Judgments of self-perceived academic competence and their differential impact on students' achievement motivation, learning approach, and academic performance. *European Journal of Psychology of Education*, 25(4), 519-536.
- [49] Lent, R. W., & Brown, S. D. (2006). On conceptualizing and assessing social cognitive constructs in career research: A measurement guide. *Journal of career assessment*, 14(1), 12-35.

- [50] Lent, R. W., Miller, M. J., Smith, P. E., Watford, B. A., Lim, R. H., & Hui, K. (2016). Social cognitive predictors of academic persistence and performance in engineering: Applicability across gender and race/ethnicity. *Journal of Vocational Behavior*, 94, 79-88.
- [51] Navarro, R. L., Flores, L. Y., Lee, H. S., & Gonzalez, R. (2014). Testing a longitudinal social cognitive model of intended persistence with engineering students across gender and race/ethnicity. *Journal of Vocational Behavior*, 85(1), 146-1.
- [52] Lee, W., Lee, M. J., & Bong, M. (2014). Testing interest and self-efficacy as predictors of academic self-regulation and achievement. *Contemporary Educational Psychology*, 39(2), 86-99.
- [53] Lent, R. W., Brown, S. D., & Larkin, K. C. (1987). Comparison of three theoretically derived variables in predicting career and academic behavior: Self-efficacy, interest congruence, and consequence thinking. *Journal of counseling psychology*, 34(3), 293.